

CATALOG NUMBER : 06K4F7W

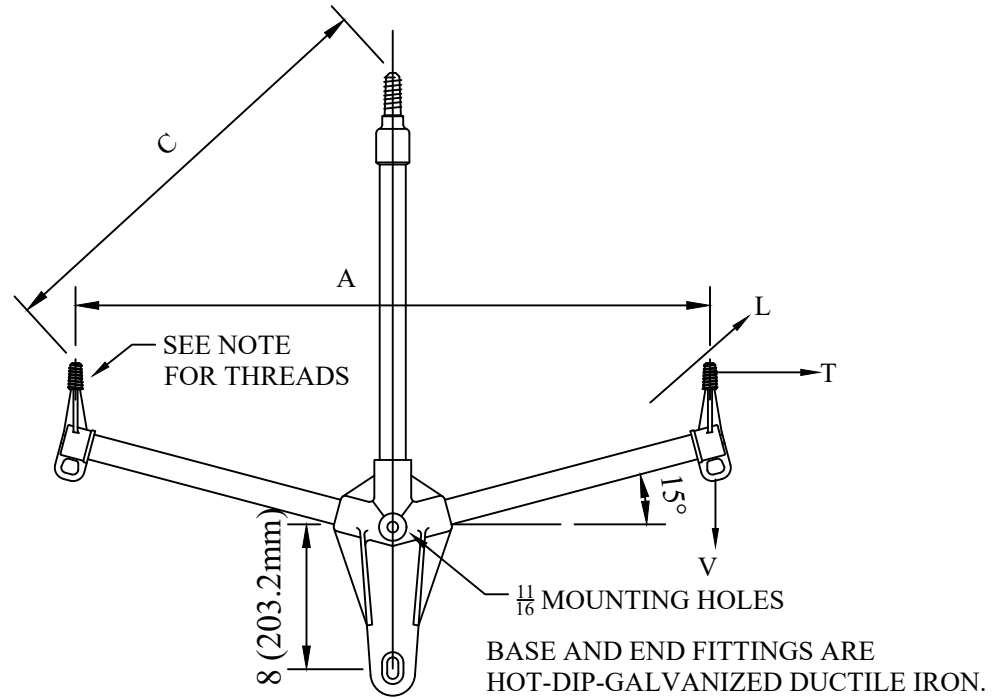

NYLON  
THREAD  
OPTION



CATALOG NUMBER	LENGTH A	LENGTH C	MINIMUM ULTIMATE *			WEIGHT (EACH)
			VERTICAL V	LONGITUDINAL L	TRANSVERSE T	
MEDIUM DUTY 1 1/2" (38.1mm) DIA. FIBERGLASS ROD						
06K4F7W_1	30 (762mm)	24 (609.6mm)	1500LBS. (608KG)	900LBS. (408KG)	1500LBS. (608KG)	18.7LBS. (8.4KG)
06K4F7W_2	48 (1219.2mm)	28 (711.2mm)	1350LBS. (612KG)	800LBS. (363KG)	1500LBS. (608KG)	19.8LBS. (8.9KG)

\* RECOMMENDED MAXIMUM WORKING LOAD IS 50% OF MINIMUM ULTIMATE RATINGS LISTED.

DRN BY:	DATA
Ella	09/07/17
<small>CONFIDENTIAL THIS DRAWING AND ITS CONTENTS PROPERTY OF TIANJIN TUOFA ELECTRIC POWER TECHNOLOGY CO.,LTD. NO PUBLICATION, DISTRIBUTION OR COPIES MAY BE MADE WITHOUT THE WRITTEN CONSENT OF TIANJIN TUOFA ELECTRIC POWER TECHNOLOGY CO.,LTD. TIANJIN TUOFA ELECTRIC POWER TECHNOLOGY CO.,LTD UNPUBLISHED ALL RIGHTS RESERVED UNDER THE COPYRIGHT LAWS.</small>	

**THREE-PHASE VERTICAL PIN  
STANDOFF BRACKET**



**TTF POWER TECHNOLOGY CO.**