

CATALOG NUMBER : 06K0A3S

NOTES:

1.MATERIAL: STEEL.

2.FINISH: HOT DIP GALVANIZE PER ASTM A153(LATEST REVISION).

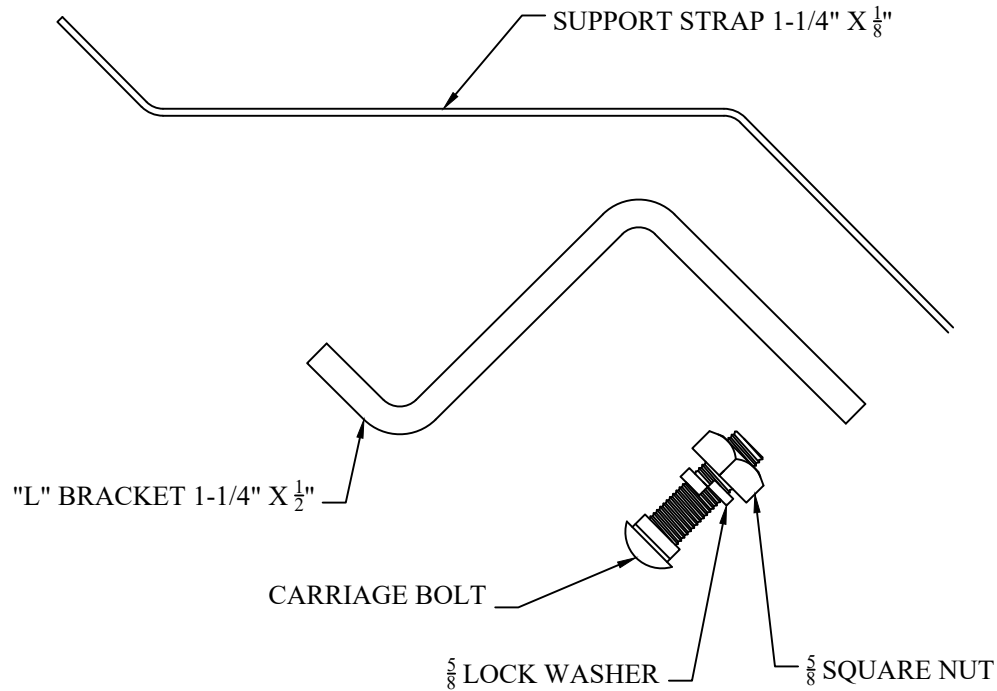

APPLICATION VIEW

NOTE - ADDITIONAL COMPONENTS SHOWN IN APPLICATION VIEW ARE NOT INCLUDED

DRN BY:	DATA
Ella	08/06/17

CONFIDENTIAL THIS DRAWING AND ITS CONTENTS PROPERTY OF TIANJIN TUOFA ELECTRIC POWER TECHNOLOGY CO.,LTD. NO PUBLICATION, DISTRIBUTION OR COPIES MAY BE MADE WITHOUT THE WRITTEN CONSENT OF TIANJIN TUOFA ELECTRIC POWER TECHNOLOGY CO.,LTD. TIANJIN TUOFA ELECTRIC POWER TECHNOLOGY CO.,LTD UNPUBLISHED ALL RIGHTS RESERVED UNDER THE COPYRIGHT LAWS.

### MESSENGER SUSPENSION BRACKET



TTF POWER TECHNOLOGY CO.