

CATALOG NUMBER : 04D9N0C

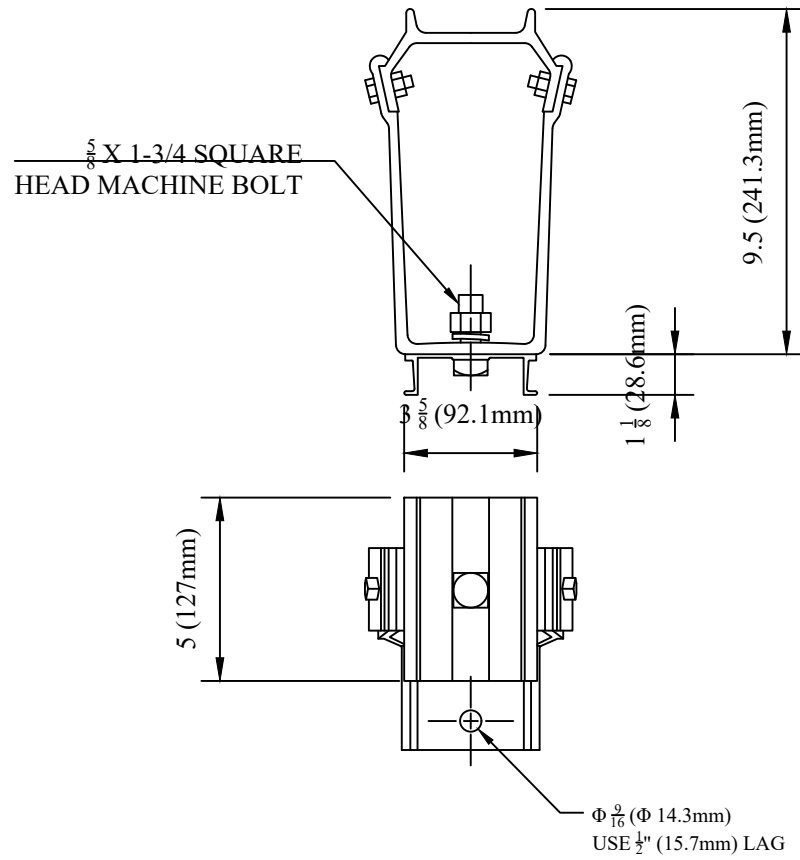

NOTES:

- 1.MATERIAL: BRACKET, ALUMINUM.
HARDWARE, GALVANIZED STEEL.
- 2.ASSEMBLED COMPLETE AS SHOWN.

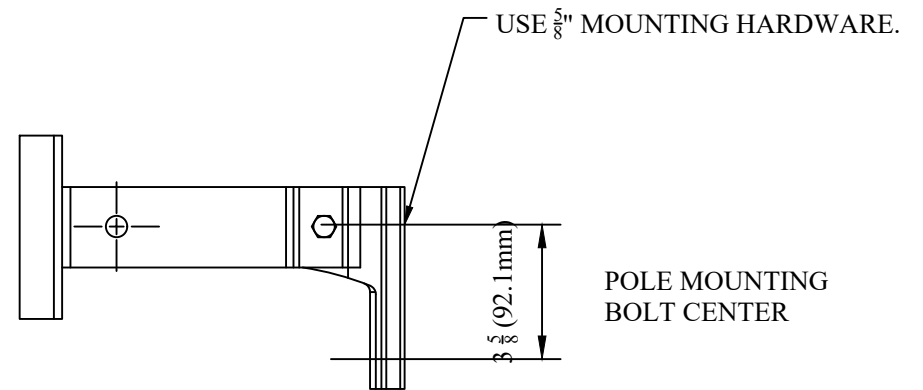

DRN BY:	DATA
Ella	09/07/17
<small>CONFIDENTIAL THIS DRAWING AND ITS CONTENTS PROPERTY OF TIANJIN TUOFA ELECTRIC POWER TECHNOLOGY CO.,LTD. NO PUBLICATION, DISTRIBUTION OR COPIES MAY BE MADE WITHOUT THE WRITTEN CONSENT OF TIANJIN TUOFA ELECTRIC POWER TECHNOLOGY CO.,LTD. TIANJIN TUOFA ELECTRIC POWER TECHNOLOGY CO.,LTD UNPUBLISHED ALL RIGHTS RESERVED UNDER THE COPYRIGHT LAWS.</small>	

ALUMINUM SINGLE POSITION BRACKET



TTF POWER TECHNOLOGY CO.