

CATALOG NUMBER : 09C4S1H

NOTES:

1.MATERIAL: STEEL CONFORMING TO THE FOLLOWING PROPERTIES:

- AVERAGE MINIMUM ABSORPTION OF 20J WHEN TESTED AT -20°C PER ASTM A370.
- MINIMUM BOLT STRENGTH CLASS 4.6 PER ASTM F568M.
- MUST BE GALVANIZABLE (SULICON 0 - .04 OR .15% - .25%).

2.ZINC COATING: HOT DIP GALVANIZE PER CSA G 164M (LATEST REVISION).

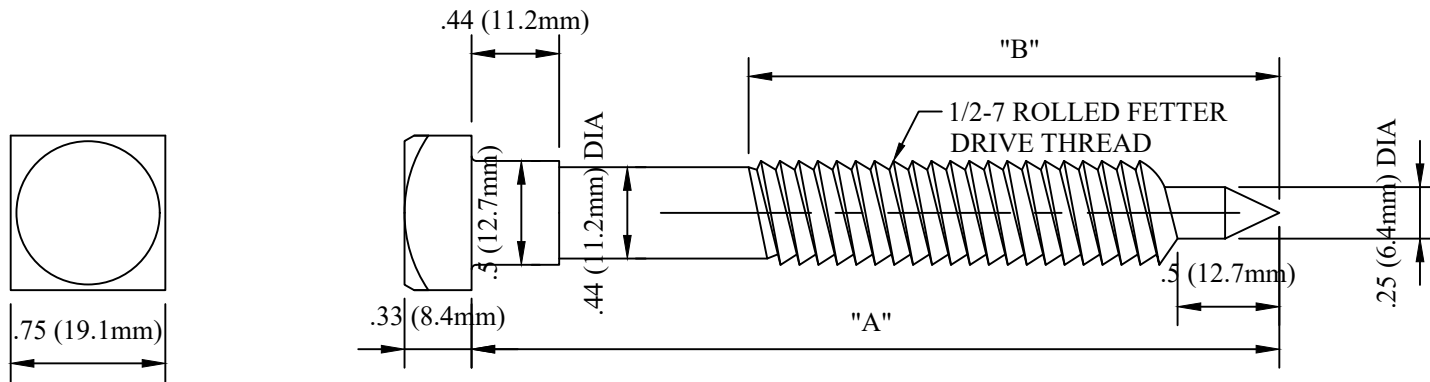

CATALOG NUMBER	"A"	"B"
09C4S1H_1	4 (101.6)	2.6 (66)
09C4S1H_2	4.5 (114.3)	3 (76.2)

DRN BY:	DATA
Ella	12/12/16

SQUARE HEAD LAG SCREW

CONFIDENTIAL THIS DRAWING AND ITS CONTENTS PROPERTY OF TIANJIN TUOFA ELECTRIC POWER TECHNOLOGY CO.,LTD. NO PUBLICATION, DISTRIBUTION OR COPIES MAY BE MADE WITHOUT THE WRITTEN CONSENT OF TIANJIN TUOFA ELECTRIC POWER TECHNOLOGY CO.,LTD. TIANJIN TUOFA ELECTRIC POWER TECHNOLOGY CO.,LTD UNPUBLISHED ALL RIGHTS RESERVED UNDER THE COPYRIGHT LAWS.



TTF POWER TECHNOLOGY CO.