

CATALOG NUMBER : 09C6X4I

NOTES:

- 1.MATERIAL: STEEL, HOT DIP GALVANIZE PER ASTM A153 (LATEST REVISION).
- 2.CONFORMS TO ASME B18.22.2.

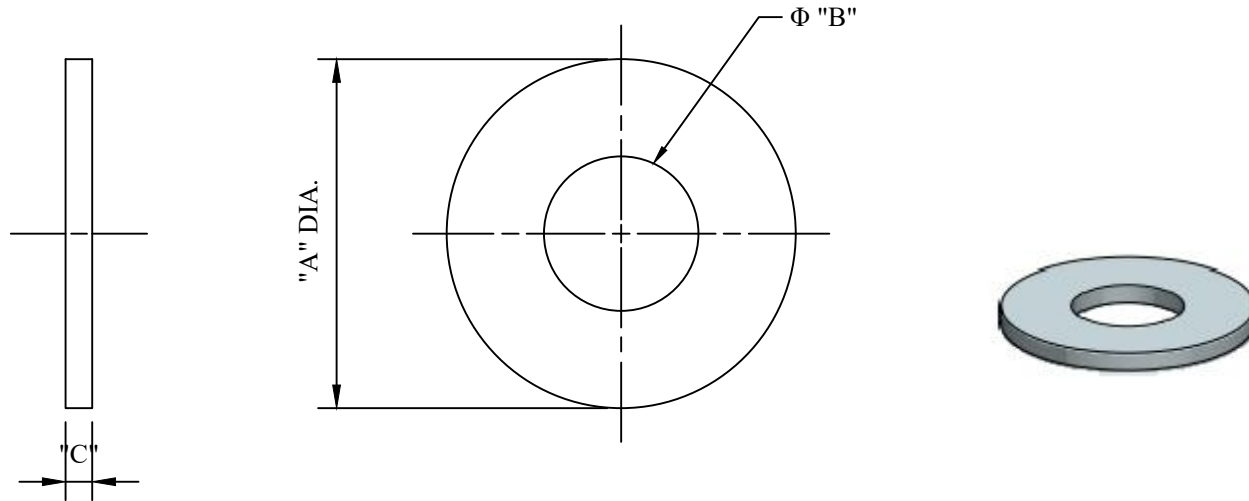

| CATALOG NUMBER | "A"          | "B"          | "C"    |
|----------------|--------------|--------------|--------|
| 09C6X4I_1      | 3/4 (19.1)   | 5/16 (7.9)   | 16 GA. |
| 09C6X4I_2      | 1 (25.4)     | 7/16 (1.1)   | 14 GA. |
| 09C6X4I_3      | 1-1/4 (31.8) | 9/16 (14.3)  | 14 GA. |
| 09C6X4I_4      | 1-3/8 (34.9) | 9/16 (14.3)  | 12 GA. |
| 09C6X4I_5      | 1-3/4 (44.5) | 11/16 (17.5) | 11 GA. |
| 09C6X4I_6      | 2 (50.8)     | 13/16 (20.6) | 9 GA.  |
| 09C6X4I_7      | 2.5 (63.5)   | 1-1/16 (27)  | 8 GA.  |
| 09C6X4I_8      | 2.25 (57.2)  | 15/16 (23.8) | 8 GA.  |

|   |          |
|---|----------|
| DRN BY:   | DATA     |
| Ella  | 12/12/16 |
| <small>CONFIDENTIAL THIS DRAWING AND ITS CONTENTS PROPERTY OF TIANJIN TUOFA ELECTRIC POWER TECHNOLOGY CO.,LTD. NO PUBLICATION, DISTRIBUTION OR COPIES MAY BE MADE WITHOUT THE WRITTEN CONSENT OF TIANJIN TUOFA ELECTRIC POWER TECHNOLOGY CO.,LTD. TIANJIN TUOFA ELECTRIC POWER TECHNOLOGY CO.,LTD UNPUBLISHED ALL RIGHTS RESERVED UNDER THE COPYRIGHT LAWS.</small> |          |

GALVANIZED STEEL ROUND WASHER



TTF POWER TECHNOLOGY CO.