

CATALOG NUMBER : 04D9B5I

NOTES:

- 1.MATERIAL: HOT ROLLED STEEL.
- 2.FINISH: HOT DIP GALVANIZE PER ASTM A153(LATEST REVISION).

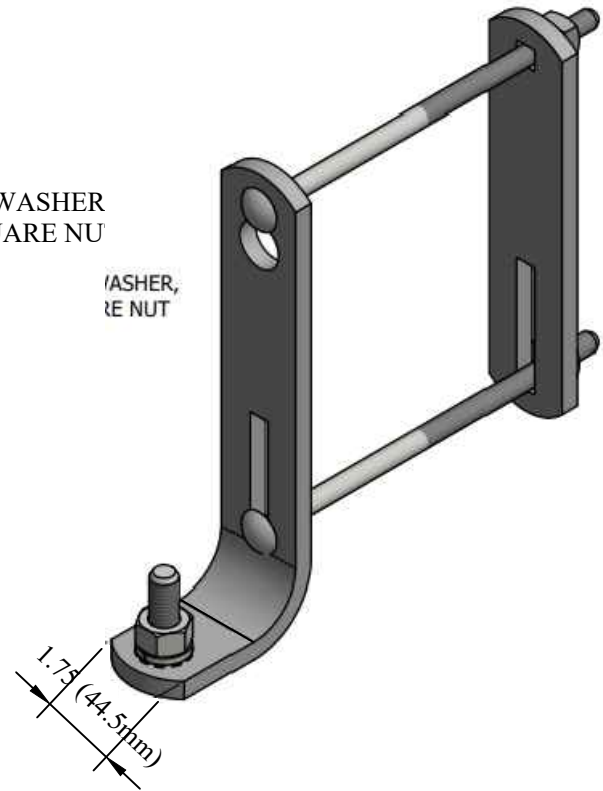
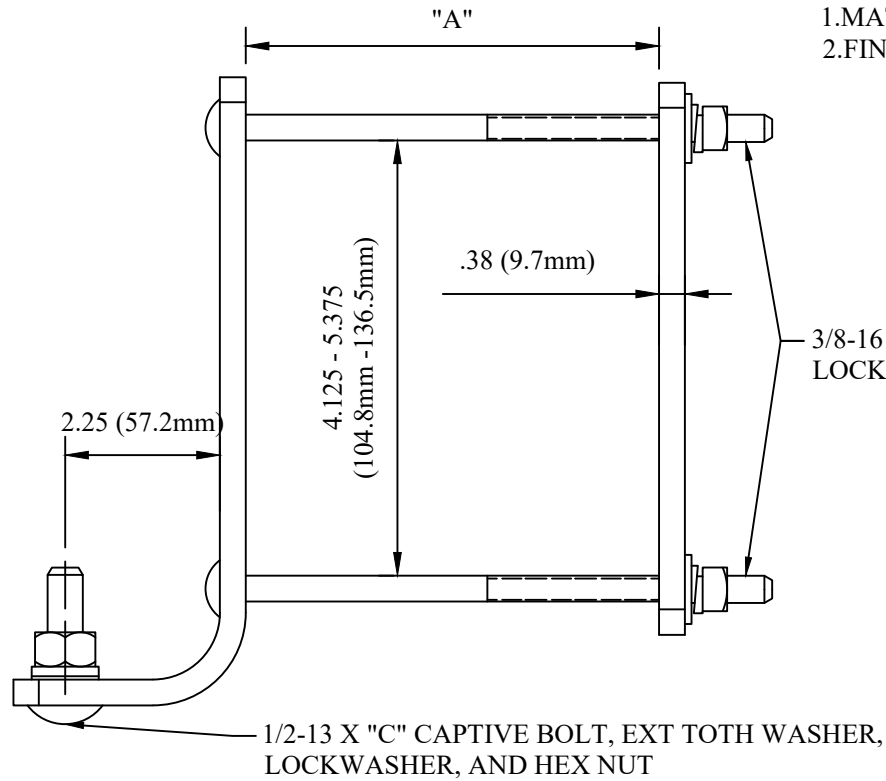

CATALOG NUMBER	"A"	"B"	"C"
04D9B5I_1	3 1/2 - 6 (88.9 - 152.4)	8 (203.2)	2 (50.8)
04D9B5I_2	3 1/2 - 6 (88.9 - 152.4)	8 (203.2)	1.5 (38.1)
04D9B5I_3	2 3/4 - 4 (69.9 - 101.6)	6 (152.4)	2 (50.8)
04D9B5I_4	2 3/4 - 4 (69.9 - 101.6)	6 (152.4)	1.5 (38.1)
04D9B5I_5	2 3/4 - 4.5 (69.9 - 114.3)	6.5 (165.1)	2 (50.8)

DRN BY:	DATA
Ella	12/12/16

CONFIDENTIAL THIS DRAWING AND ITS CONTENTS PROPERTY OF TIANJIN TUOFA ELECTRIC POWER TECHNOLOGY CO.,LTD. NO PUBLICATION, DISTRIBUTION OR COPIES MAY BE MADE WITHOUT THE WRITTEN CONSENT OF TIANJIN TUOFA ELECTRIC POWER TECHNOLOGY CO.,LTD. TIANJIN TUOFA ELECTRIC POWER TECHNOLOGY CO.,LTD UNPUBLISHED ALL RIGHTS RESERVED UNDER THE COPYRIGHT LAWS.

CROSSARM MOUNTED  
CUTOUT-ARRESTER BRACKET



TTF POWER TECHNOLOGY CO.