

CATALOG NUMBER : 06H139F

NOTES:

- 1.MATERIAL: STEEL.
- 2.FINISH: HOT DIP GALVANIZE PER ASTM A153 (LATEST REV.)
- 3. 2.38" OD EQUALS 2" IPS

FEATURES:

3/8"GROUNDING HARDWARE INCLUDED

WEIGHT EA (LBS) : 12.0

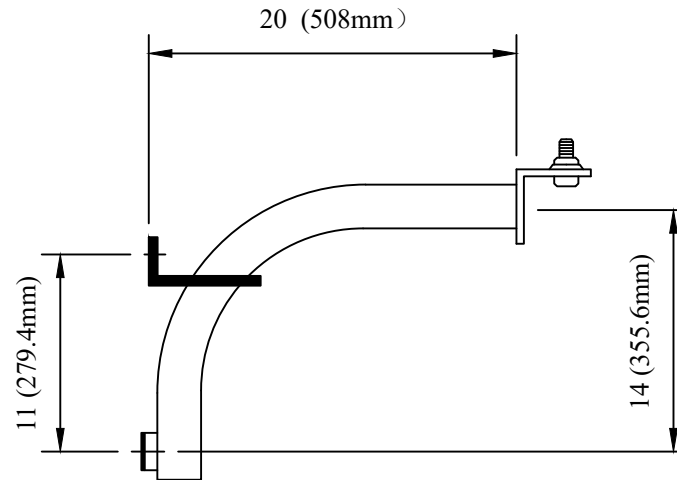
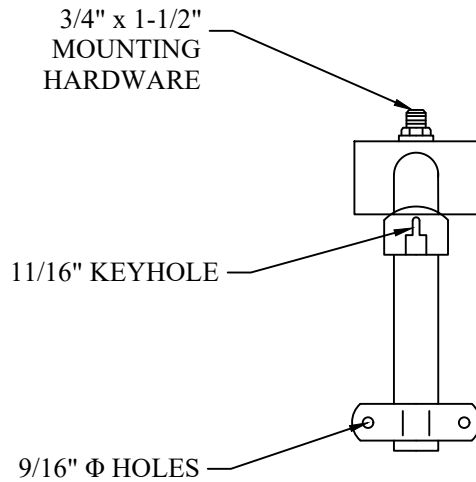
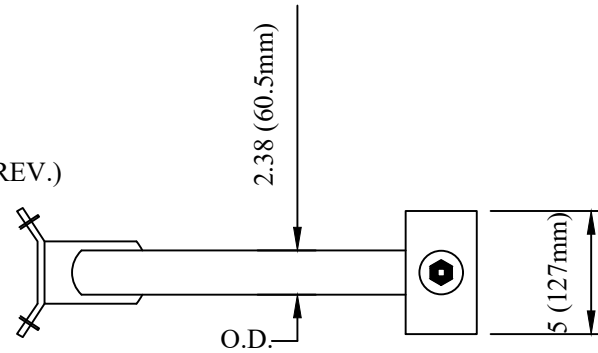

DRN BY:	DATA
Ella	10/08/16
CONFIDENTIAL THIS DRAWING AND ITS CONTENTS PROPERTY OF TIANJIN TUOFA ELECTRIC POWER TECHNOLOGY CO.,LTD. NO PUBLICATION, DISTRIBUTION OR COPIES MAY BE MADE WITHOUT THE WRITTEN CONSENT OF TIANJIN TUOFA ELECTRIC POWER TECHNOLOGY CO.,LTD. TIANJIN TUOFA ELECTRIC POWER TECHNOLOGY CO.,LTD UNPUBLISHED ALL RIGHTS RESERVED UNDER THE COPYRIGHT LAWS.	

MAST ARM, FLOODLIGHT,
WOOD POLE MOUNTING (A)



TTF POWER TECHNOLOGY CO.