

CATALOG NUMBER : 06C3MMM

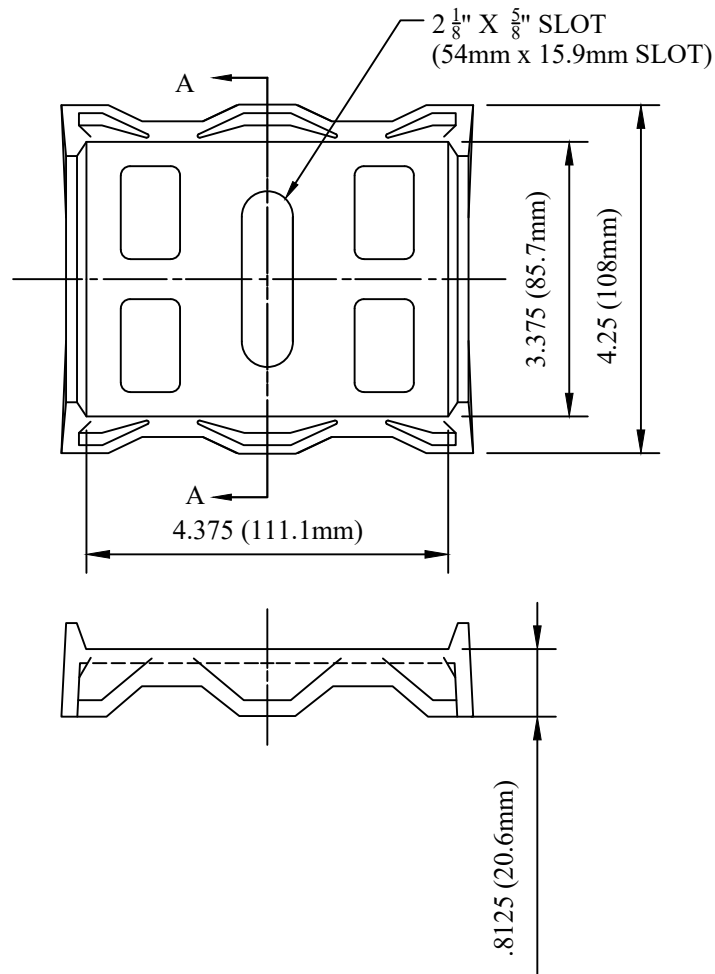

NOTES:

- 1.MATERIAL: DUCTILE IRON PER ASTM A536.
- 2.FINISH: HOT DIP GALVANIZE PER ASTM A153(LATEST REV.)

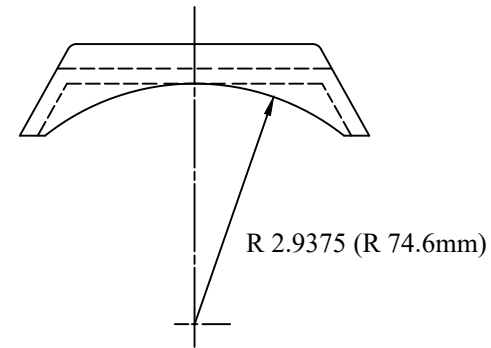

DRN BY:	DATA
Ella	10/08/16
<small>CONFIDENTIAL THIS DRAWING AND ITS CONTENTS PROPERTY OF TIANJIN TUOFA ELECTRIC POWER TECHNOLOGY CO.,LTD. NO PUBLICATION, DISTRIBUTION OR COPIES MAY BE MADE WITHOUT THE WRITTEN CONSENT OF TIANJIN TUOFA ELECTRIC POWER TECHNOLOGY CO.,LTD. TIANJIN TUOFA ELECTRIC POWER TECHNOLOGY CO.,LTD UNPUBLISHED ALL RIGHTS RESERVED UNDER THE COPYRIGHT LAWS.</small>	

GAIN FOR CROSSARM,
4-1/4 IN X 4-3/8 IN,GALVANIZED, ASTM
A-153_GC414438W0504



TTF POWER TECHNOLOGY CO.