

CATALOG NUMBER : 05G5C9W

CONDUCTOR DIA. RANGE INCHES [MM]	ULT. BODY STRENGTH(LBS)	RODS PER SET
0.711-0.731 [18.06-18.57]	15000	12

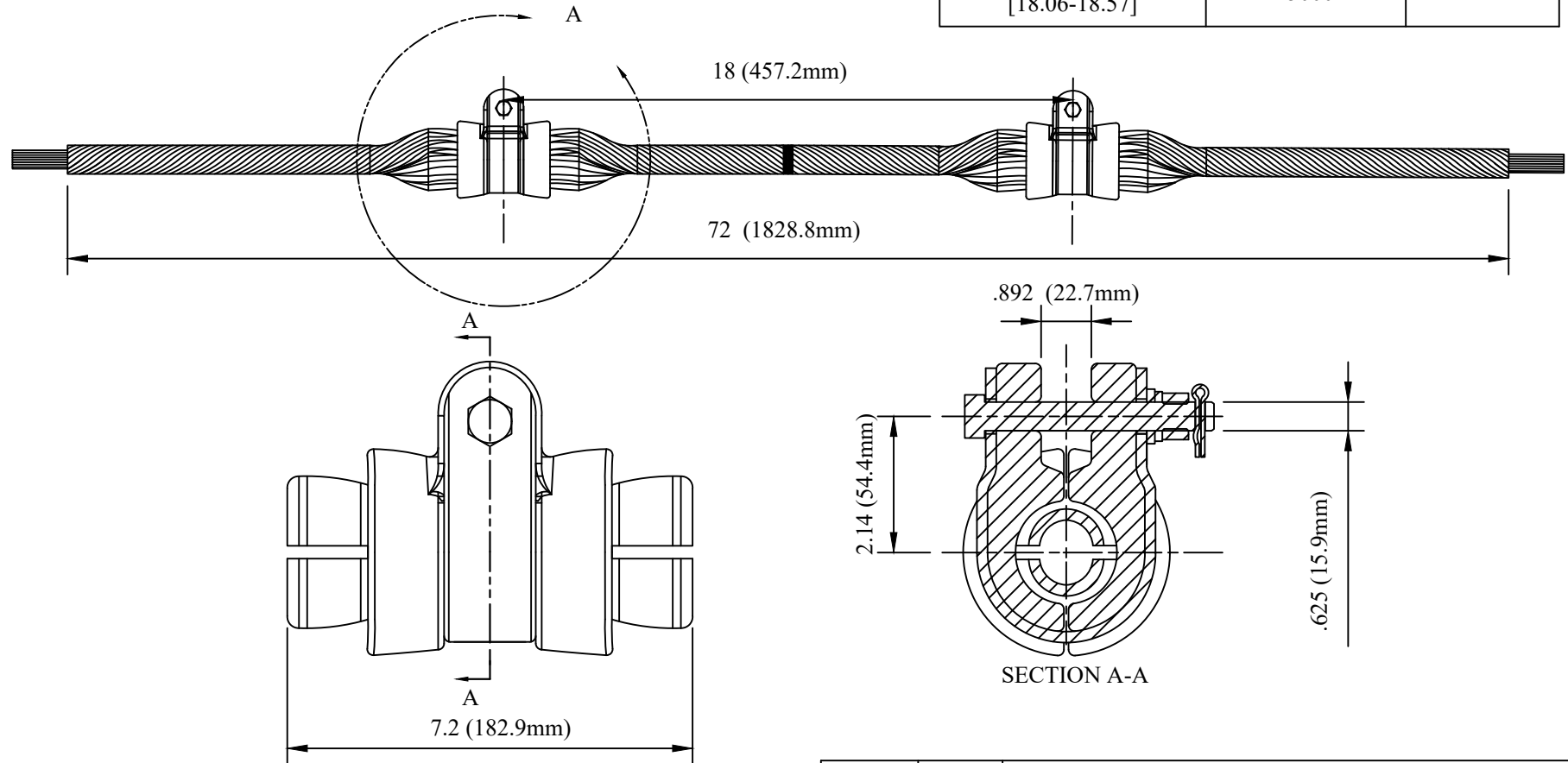

NOTES:

- 1.MATERIAL:CLAMP BODY,STRAP - ALUMINUM ALLOY
RUBBER INSERT - EPDM RUBBER
HELICAL RODS - ALUMINUM ALLOY
HARDWARE (BOLT,NUT,FLAT WASHER & LOCK WASHER) - GALV. STEEL
COTTER PIN - STAINLESS STEEL

2.DIMENSIONS IN INCHES[MILLIMETER]

3.MAXIMUM TAKE OFF ANGLE = 30° - 60°

4.SLIP LOAD IS 15 - 20% OF CONDUCTOR RBS. CONTACT HUBBELL FOR MORE INFORMTION.

5.BODY,STRAP AND RUBBER INSERT CAN BE IDENTIFIED BY THE CONDUCTOR RANGE MARKED ON THEM. HELICAL RODS HAVE CONDUCTOR RANGE MARKED IN A TAG ATTACHED TO THE BUNDLE AS WELL AS THE COLOR PAINT MARK.PLEASE NOTE SOME PARTS HAVE LARGER AND CAN BE USED ON MULTIPLE SIZES.

DETAIL A

DRN BY:	DATA
Ella	07/09/16
<small>CONFIDENTIAL-THIS DRAWING AND ITS CONTENTS PROPERTY OF TIANJIN TUOFA ELECTRIC POWER TECHNOLOGY CO.,LTD. NO PUBLICATION, DISTRIBUTION OR COPIES MAY BE MADE WITHOUT THE WRITTEN CONSENT OF TIANJIN TUOFA ELECTRIC POWER TECHNOLOGY CO.,LTD. TIANJIN TUOFA ELECTRIC POWER TECHNOLOGY CO.,LTD UNPUBLISHED ALL RIGHTS RESERVED UNDER THE COPYRIGHT LAWS.</small>	

SUSPENSION CLAMP,
RANGE 0.284 IN -0.294 IN



TTF POWER TECHNOLOGY CO.