

CATALOG NUMBER : 04G2U2J

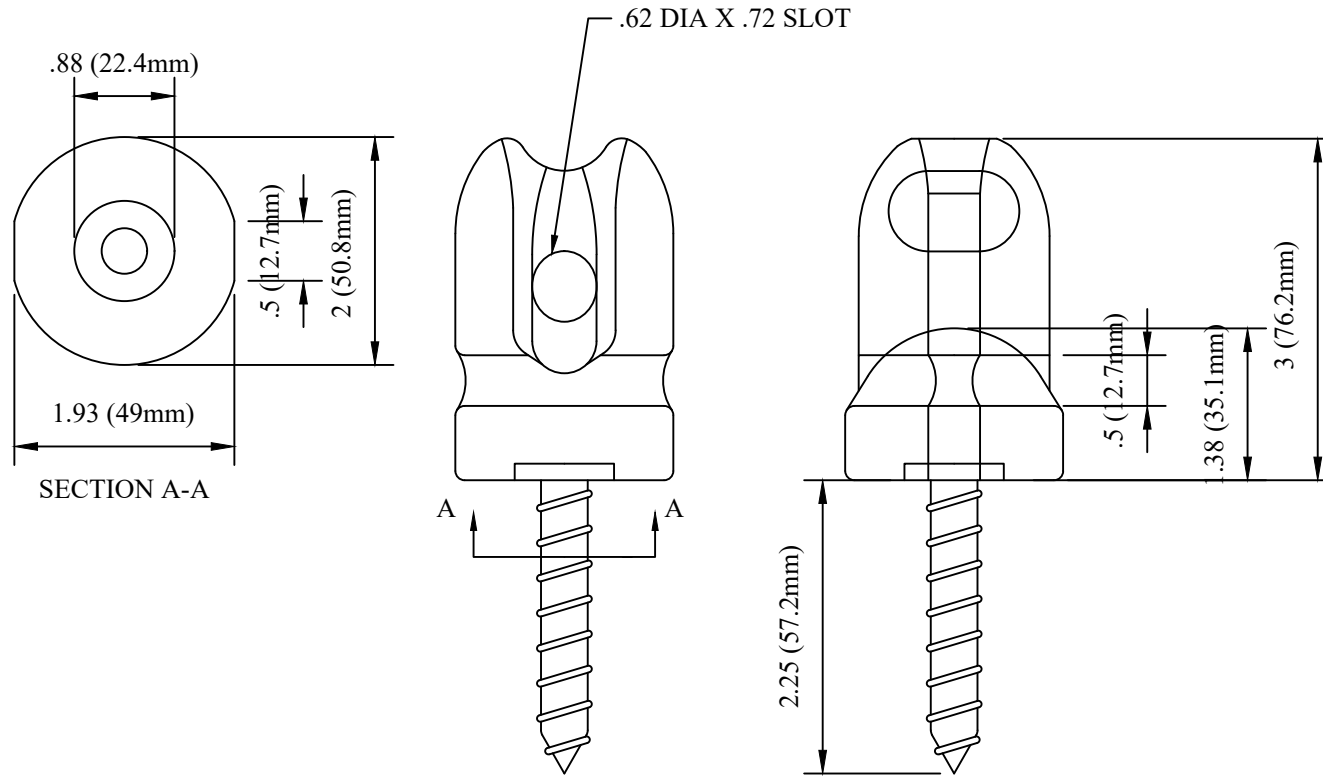

NOTES:

- 1.MATERIAL: PORCELAIN, FINISH - WHITE OR GREY GLAZED.
- 2.#22 WOOD SCREW, GIMLET POINT, 7 OR 8 THREADS PER INCH. GALVANIZE PER ASTM A153 OR ZINC ELECTROPLATING PER ASTM B633.

DRN BY:	DATA
Ella	07/09/16
<small>CONFIDENTIAL THIS DRAWING AND ITS CONTENTS PROPERTY OF TIANJIN TUOFA ELECTRIC POWER TECHNOLOGY CO.,LTD. NO PUBLICATION, DISTRIBUTION OR COPIES MAY BE MADE WITHOUT THE WRITTEN CONSENT OF TIANJIN TUOFA ELECTRIC POWER TECHNOLOGY CO.,LTD. TIANJIN TUOFA ELECTRIC POWER TECHNOLOGY CO.,LTD UNPUBLISHED ALL RIGHTS RESERVED UNDER THE COPYRIGHT LAWS.</small>	

SERVICE WIREHOLDER,
5/8 IN WIDTH



TTF POWER TECHNOLOGY CO.