

CATALOG NUMBER : 06H4N4X

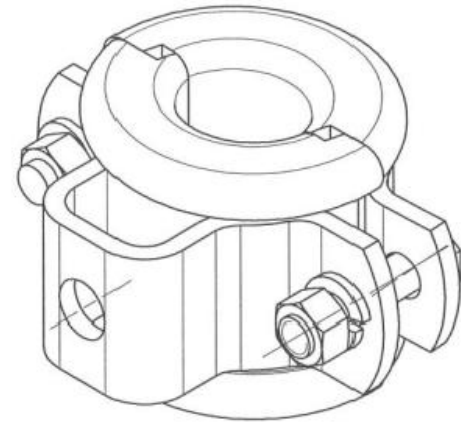
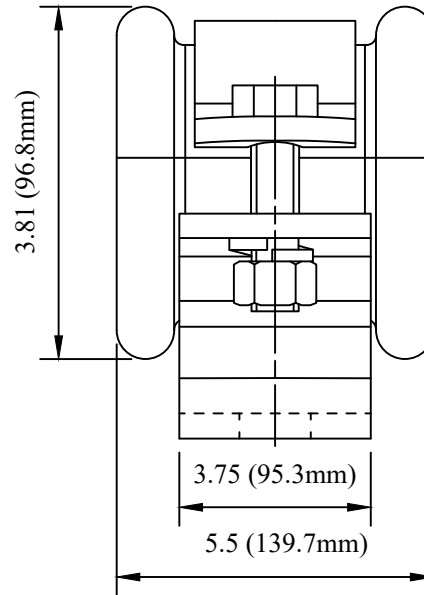
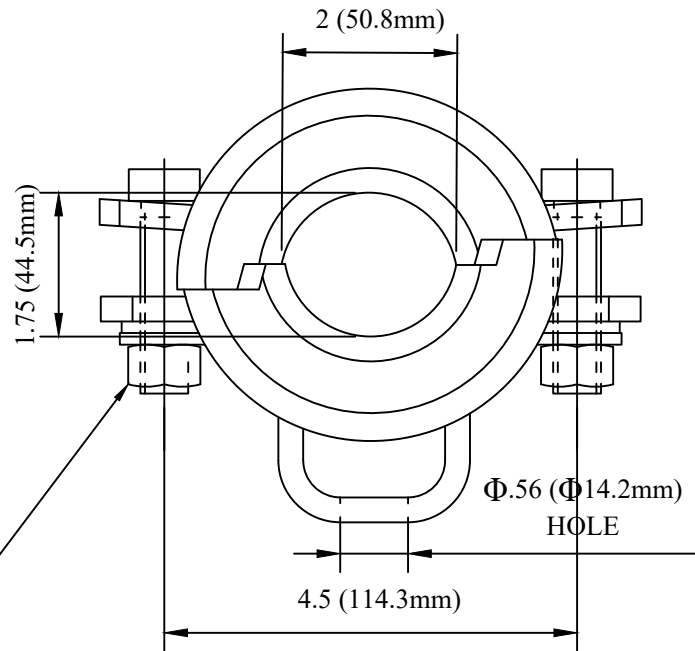

3/8-16-UNC HEX NUT AND BOLT
W-3/8 SPRING LOCK WASHER

NOTES:

- 1.MATERIAL: MOUNTING BRACKET: STEEL PER TT-169
BACK STRAP: ALUMINUM ALLOY 5052-H32
INSULATOR: COMMERCIAL GRADE DRY PROCESS PORCELAIN.
- 2.FINISH: MOUNTING BRACKET: HOT DIP GALVANIZE PER ASTM A153(LATEST REV.)
INSULATOR: WHITE GLAZE.

DRN BY:	DATA
Ella	07/09/16
<small>CONFIDENTIAL THIS DRAWING AND ITS CONTENTS PROPERTY OF TIANJIN TUOFA ELECTRIC POWER TECHNOLOGY CO.,LTD. NO PUBLICATION, DISTRIBUTION OR COPIES MAY BE MADE WITHOUT THE WRITTEN CONSENT OF TIANJIN TUOFA ELECTRIC POWER TECHNOLOGY CO.,LTD. TIANJIN TUOFA ELECTRIC POWER TECHNOLOGY CO.,LTD UNPUBLISHED ALL RIGHTS RESERVED UNDER THE COPYRIGHT LAWS.</small>	

PORCELAIN CABLE SUPPORT,
3.02 LB



TTF POWER TECHNOLOGY CO.