

CATALOG NUMBER : 05E7Y5W

CATALOG NUMBER	DESCRIPTION	MATERIAL	QUANTITY
05E7Y5W_1	TOP CASTING	TIN PLATED BRASS	1
05E7Y5W_2	FLANGE BOLT, $\frac{5}{16}$ "-18 X 1"	SILICON BRONZE	1
05E7Y5W_3	BOTTOM CASTING	TIN PLATED BRONZE	1

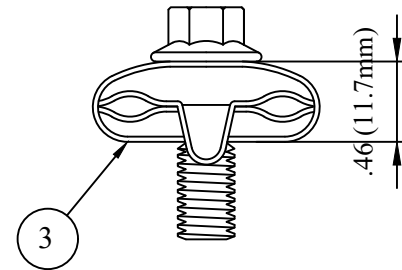
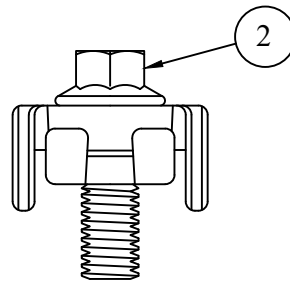
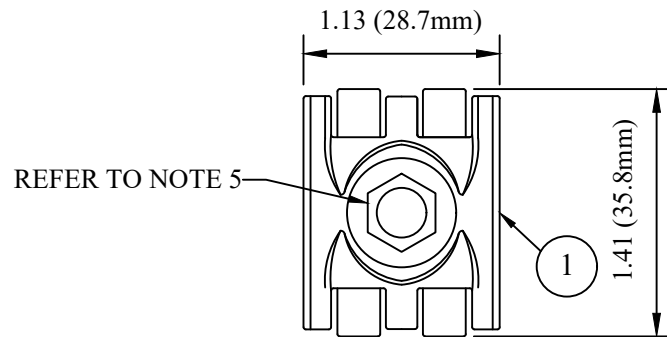

NOTES:

- 1.FOR MANUFACTURING DETAILS, PEFER TO:  
PP-26135 FOR BOTTOM CASTING  
PP-26136 FOR TOP CASTING
- 2.RECOMMENDED TORQUE: 180 IN. - LBS.
- 3.FOR USE ON 1/4" - 7/16" STRANDED.
- 4.ALL DIMENSIONS IN INCHES.
- 5.FOR BARE GROOVE "BG" OPTION, TIN PLATING IS REMOVED FROM ONE SINGLE GROOVE OF EACH CASTING.

DRN BY:	DATA
Ella	10/10/16
<small>CONFIDENTIAL THIS DRAWING AND ITS CONTENTS PROPERTY OF TIANJIN TUOFA ELECTRIC POWER TECHNOLOGY CO.,LTD. NO PUBLICATION, DISTRIBUTION OR COPIES MAY BE MADE WITHOUT THE WRITTEN CONSENT OF TIANJIN TUOFA ELECTRIC POWER TECHNOLOGY CO.,LTD. TIANJIN TUOFA ELECTRIC POWER TECHNOLOGY CO.,LTD UNPUBLISHED ALL RIGHTS RESERVED UNDER THE COPYRIGHT LAWS.</small>	

BONDING CLAMP



TTF POWER TECHNOLOGY CO.