

CATALOG NUMBER : 06P4H3J

NOTES:

1.ASSEMBLIES COMPLETE AS SHOWN.

2.INSTALLATION INSTRUCTIONS:

- MEASURE CIRCUMFERENCE OF POLE WHERE BAND IS TO BE INSTALLED
- CUT BAND TO LENGTH 8" -12" BEYOND MEASURED DISTANCE PLUS WHATEVER IS CALCULATED FOR ADDITIONAL HARDWARE BEING INSTALLED.
- SLIDE BAND INTO FIXED END (AT BOLT HEAD) AND BEND 4"-6" ONTO ITSELF THUS CAPTURING ALUMINUM RETAINER.
- REPEAT THIS FOR THE SLIDING END.
- PLACE BANDED ASSEMBLY AROUND POLE AT DESIRED LOCATION INSTALLING THE CARRIAGE BOLT THROUGH THE TWO ALUMINUM ENDS.
- INSTALL NUT AND TIGHTEN UNTIL ASSEMBLY IS SECURE AND ALL SLACK HAS BEEN TAKEN UP.

ALUMINUM CLAMP BODY

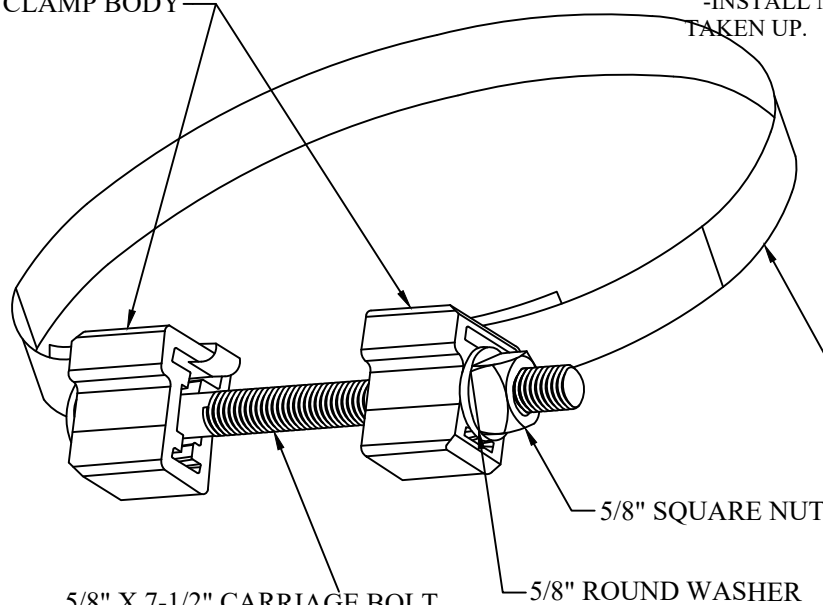

W1-1/4" x 132" x 0.044 THICKNESS STAINLESS STEEL BAND.
(95,000 PSI TENSILE STRENGTH
15,000PSI YIELD STRENGTH)

5/8" SQUARE NUT

5/8" ROUND WASHER

5/8" X 7-1/2" CARRIAGE BOLT

CATALOG NUMBER	"L"
06P4H3J_1	36" (914.4)
06P4H3J_2	40" (1016)
06P4H3J_3	48" (1219.2)
06P4H3J_4	62" (1574.8)
06P4H3J_5	74" (1879.6)
06P4H3J_6	86" (2184.4)
06P4H3J_7	62" (3352.8)

DRN BY:	DATA
Ella	07/09/16

BANDING AND BUCKLE KIT

CONFIDENTIAL THIS DRAWING AND ITS CONTENTS PROPERTY OF TIANJIN TUOFA ELECTRIC POWER TECHNOLOGY CO.,LTD. NO PUBLICATION, DISTRIBUTION OR COPIES MAY BE MADE WITHOUT THE WRITTEN CONSENT OF TIANJIN TUOFA ELECTRIC POWER TECHNOLOGY CO.,LTD. TIANJIN TUOFA ELECTRIC POWER TECHNOLOGY CO.,LTD UNPUBLISHED ALL RIGHTS RESERVED UNDER THE COPYRIGHT LAWS.



TTF POWER TECHNOLOGY CO.