

CATALOG NUMBER : 04H3O7B

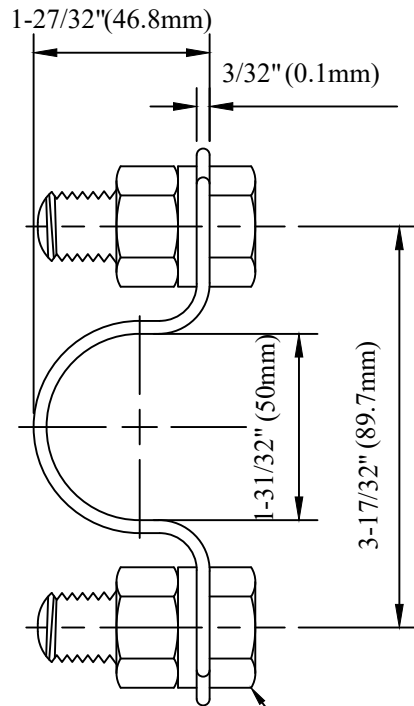

1/2" X 2" BOLT
NUT, LOCKWASHER

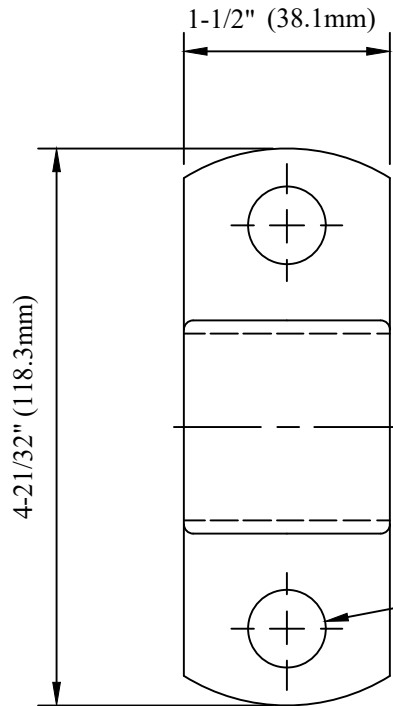

9/16" (0.6mm) HOLE

NOTES:

1. ALL STRAP MATERIAL IS ALUMINUM. BOLTS, NUTS, AND WASHERS ARE GALVANIZED STEEL.
2. CONDUIT STRAP AVAILABLE WITH OR W/O 1/2" MOUNTING BOLTS, NUTS, AND LOCKWASHERS.

DRN BY:	DATA
Ella	07/09/16
<small>CONFIDENTIAL THIS DRAWING AND ITS CONTENTS PROPERTY OF TIANJIN TUOFA ELECTRIC POWER TECHNOLOGY CO.,LTD. NO PUBLICATION, DISTRIBUTION OR COPIES MAY BE MADE WITHOUT THE WRITTEN CONSENT OF TIANJIN TUOFA ELECTRIC POWER TECHNOLOGY CO.,LTD. TIANJIN TUOFA ELECTRIC POWER TECHNOLOGY CO.,LTD UNPUBLISHED ALL RIGHTS RESERVED UNDER THE COPYRIGHT LAWS.</small>	

ALUMINUM CONDUIT BRACKET STRAP,
0.4 LB



TTF POWER TECHNOLOGY CO.