

CATALOG NUMBER : 04B1U9R

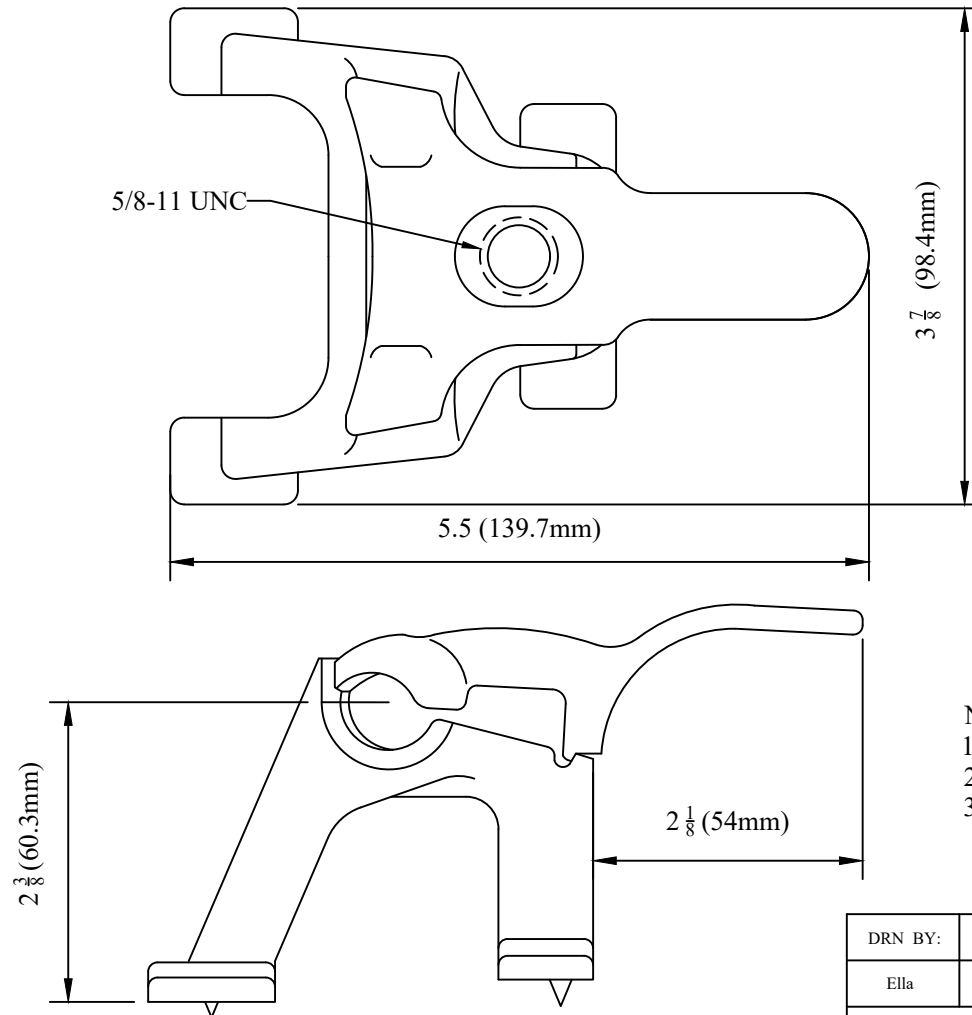

NOTES:

- 1.MATERIAL: DUCTILE IRON PER ASTM A536.
- 2.FINISH: HOT DIP GALVANIZED PER ASTM A153.
- 3.STAND RANGE: .43-.75 DIA.

DRN BY:	DATA
Ella	10/08/16
CONFIDENTIAL THIS DRAWING AND ITS CONTENTS PROPERTY OF TIANJIN TUOFA ELECTRIC POWER TECHNOLOGY CO.,LTD. NO PUBLICATION, DISTRIBUTION OR COPIES MAY BE MADE WITHOUT THE WRITTEN CONSENT OF TIANJIN TUOFA ELECTRIC POWER TECHNOLOGY CO.,LTD. TIANJIN TUOFA ELECTRIC POWER TECHNOLOGY CO.,LTD UNPUBLISHED ALL RIGHTS RESERVED UNDER THE COPYRIGHT LAWS.	

AERIAL SUSPENSION CLAMP WITH 5/8
IN HOLE IN CLAMP BASE



TTF POWER TECHNOLOGY CO.